

REO-MECH

BUILT TOUGH

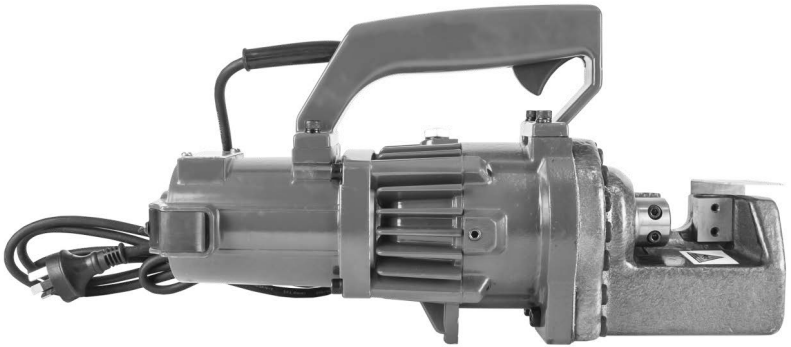

User's Guide

REO-MECH Electric Rebar Cutters

WARNING: PLEASE READ THIS MANUAL CAREFULLY BEFORE USING THIS MACHINE

Machine is not rated and should not be used for commercial rebar production purposes.

1. Safety

This machine is a high performance, electric tool. Failure to follow safety instructions may result in serious injury.

1. Authorized personal protective equipment must be worn when operating machine (minimum requirement - safety glasses and protective gloves).
2. Take note of all warning signs on machine.
3. Ensure power supply is properly earthed.
4. Keep body parts well clear of cutter blocks when machine is switched on.
5. Beware of ejected objects during the cutting process. Always wear approved safety glasses.
6. Use protective gloves when cleaning machine or handling cutter blocks as edges are very sharp.
7. Do not touch pump housing after use as it will be hot. Wait for machine to cool.
8. Use away from others, particularly children.
9. Never attempt to cut rebar outside of models prescribed diameter range (refer to table in Specifications & Parts section).
10. Never attempt to service machine (other than general maintenance procedures outlined in Maintenance section). Contact supplier if issues arise.
11. Only use REO-MECH approved spare parts and accessories with machine.
12. Do not cut short lengths.
13. Hold cutter firmly and maintain proper footing and balance. Do not use at heights.
14. Never operate machine in wet or damp conditions.
15. Keep away from sparks and naked flames.
16. Always check power cord for damage and safe placement prior to use.
17. Disconnect cutter from power outlet when not in use.
18. Inspect cutter before each use (refer to Maintenance section). Do not use when quality has been compromised.
19. Do not cover air vents on machine.
20. Store out of reach of children.
21. Where available, safety guard should be installed.

2. Specifications & Parts

Power Supply:

Ensure machine is connected to correct power supply (check machine label to confirm power supply).

Extension Leads:

Where possible, connect machine directly to power outlet. If an extension lead is required, ensure lead is under 40m in length. Minimum extension lead diameter are prescribed below:

Extension Lead Length (m)	Min Wire \varnothing (mm ²)
25m	1.5
40m	2.5

Machine Specifications

MODEL	ERC-16	ERC-20	ERCP-20	ERC-25	ERC-32
Input Voltage	Single Phase 220-240V AC ~50Hz or Single Phase 110-120V AC ~60Hz *				
Power Consumption 220-240V	900W	1000W	950W	1550W	2400W
Power Consumption 110-120V	950W	1200W	1050W	1500W	2150W
Net Weight	8kg	13kg	13kg	24kg	31kg
Dimensions (cm)	46L x 27W x 12H	41L x 12W x 22H	50L x 13W x 14H	48L x 15W x 26H	52L x 17W x 27H
Cutting Range	4-16mm**	4-20mm**	4-20mm**	4-25mm**	6-32mm**

* Check machine label to determine correct power supply.

** Refer to machine model data sheet for maximum tensile strength/grade.

Machine Parts

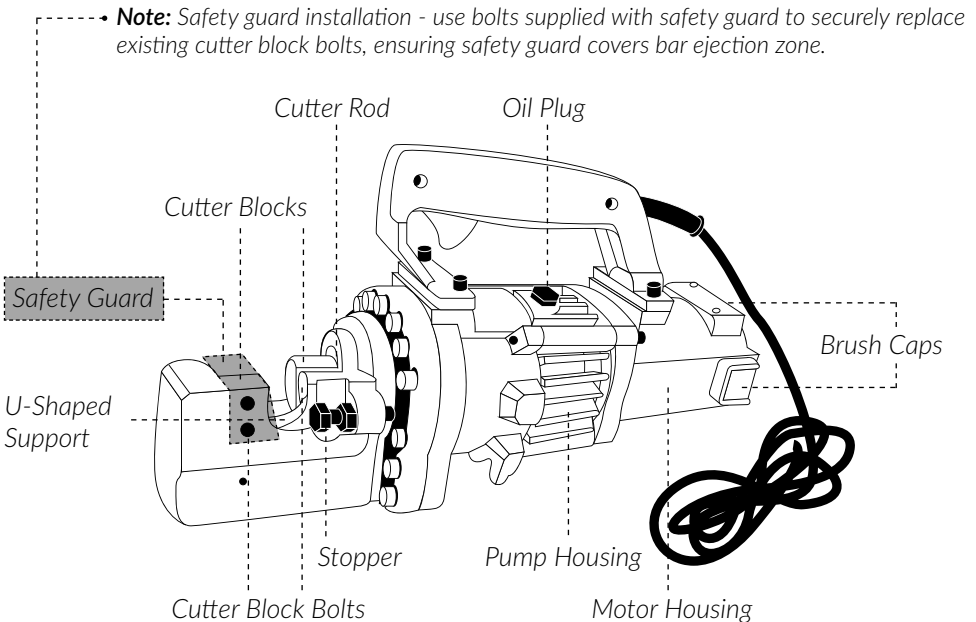

Note: Cutter body varies with different models - use as a general guide.

3. Operating Machine

Pre-use Checks:

1. Check oil level (refer to Maintenance section).
2. Check condition of cutter blocks and tightness of cutter block bolts (refer to Maintenance section).
3. Check power supply is properly earthed.
4. Check that power cord is undamaged and plug is not loose (also applies for extension leads).

Warm Up:

In cold weather, warm up unit for 60 seconds to ensure hydraulic oil reaches proper viscosity. Pull trigger and repeat cut cycle without material 15-20 times.

Stopper Adjustment:

Adjustable stopper must be set in correct position dependent on size of rebar.

1. Insert rebar into U-shaped support.
2. Keeping rebar at 90° to machine, screw in stopper until it is just touching the rebar.

Cutting Procedure:

1. Insert rebar between stopper and front cutter block, making sure it is properly seated in U-shaped support.
2. Pull and hold trigger while cutter rod advances and fully cuts rebar.
3. Release trigger only once rebar has been fully cut to allow cutter rod to retract.

Note: Power will be compromised if hydraulic oil exceeds 70 °C. Allow machine to cool before resuming operation.

4. Maintenance

Cutter Blocks:

Check cutter blocks for damage before each use. If cutter block is damaged, replace block before next use as per following diagram:

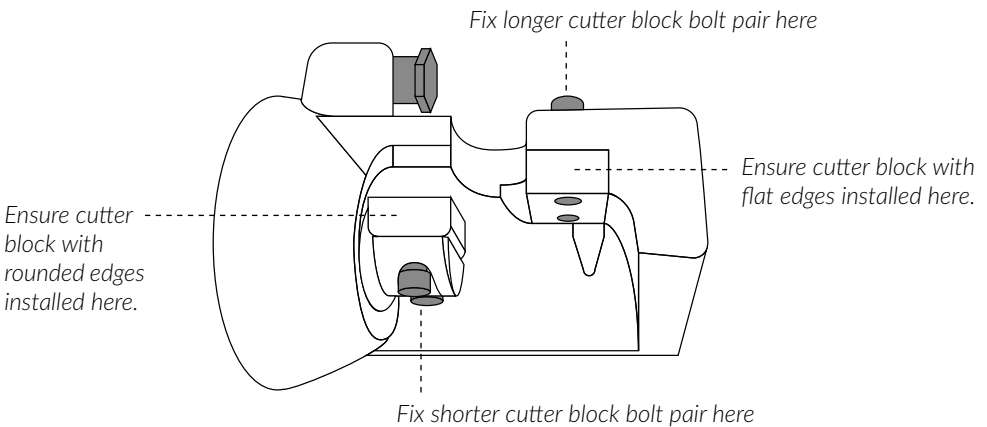

Check cutter block bolts for tightness before each use. Use protective gloves when handling cutter blocks as edges are very sharp.

Cleaning:

Clean machine after each use.

Use protective gloves when cleaning to protect hands from metal splinters.

Do not use air gun as this may cause dust and metal filings to enter vents.

1. Extend cutter rod and disconnect from power source.
2. Wipe or brush away all dust and metal filings. Pay particular attention to lower half of cutter rod.
3. Connect to power source to complete cut cycle.

Oil Level Check:

Check oil before each use. Hydraulic oil is highly flammable; keep away from sparks and naked flame. In case of ingestion or eye contact, consult a physician immediately.

1. Adjust stopper and make 3-4 cuts, noting exactly the point in which rebar is breaking.
2. Pinch next bit of rebar, stopping just before it breaks. Unplug machine from power source.
3. Turn unit over so oil plug is uppermost (if machine is hot allow to cool down first).
4. Remove oil plug and seal washer (never remove when machine is hot).
5. Check oil is level with bottom of plug hole. If oil is too low, top up with approved ISO VG46 oil.
6. Remove air bubbles - gently tilt cutter lengthways and return to level position. Top up and tilt cutter in opposite direction. Repeat this process until all air has been extracted.
7. Replace seal washer and oil plug.
8. Connect to power source and completely sever rebar.

Oil Change:

Change oil at least once a year or sooner if it appears dirty.

1. Unplug machine from power source.
2. Turn unit over so oil plug is uppermost (if machine is hot allow to cool down first).
3. Remove oil plug and seal washer (never remove when machine is hot).
4. Turn cutter over and drain oil into a suitable receptacle. When oil ceases to drain, tilt machine to rear to allow oil trapped in piston housing to drain out. When housing is empty, tilt unit in the opposite direction to empty the residue in the pump case.
5. Once all oil has been drained from the machine, turn unit over so oil plug is uppermost.
6. Slowly fill the machine with fresh oil and replace seal washer and oil plug.
7. Connect machine to power source and follow procedure for Oil Level Check.

Note: *Dispose of hydraulic oil in accordance with local regulations.*

Bolt Tightness:

All bolts should be checked for tightness on a weekly basis or after every 500 cuts (whichever comes first).

Carbon Brushes:

Inspect carbon brushes on a monthly basis. Worn brushes will result in power loss and cause irreparable damage to the armature's commutator. Check brushes immediately if a loss of power or electrical fault is experienced.

Replacing Carbon Brushes:

1. Unplug machine from power source.
2. Locate the brush caps on both sides near the back of the motor housing (remove rear cover to access brush caps on some models).
3. Open the brush caps with a screwdriver and remove carbon brushes from the machine.
4. Inspect the carbon brushes and replace where worn or damaged.
5. Reinstall new carbon brushes and brush caps securely.

REO-MECH

 ***BUILT TOUGH***

REO-MECH Manufacturing Pty Ltd

www.rapidtool.com.au